

# CHAPTER 6

## Acids and Bases

6.0	Introduction
6.1	Autoionization of Water
6.2	The <i>p</i> -Scale
6.3	Strong Acids
6.4	Weak Acids
6.5	Polyprotic Acids

6.6	Strong Bases
6.7	Weak Bases
6.8	Salts of Weak Acids and Bases
6.9	Amphiprotic Salts
6.10	Chapter Summary and Objectives
6.11	Exercises

### 6.0 INTRODUCTION

A Lewis base is a substance that contains a lone pair that can be used in a coordinate covalent bond,\* and a Lewis acid is a substance that has an empty orbital that can be used to share the lone pair in the bond. A Lewis acid-base reaction is the formation of the bond between the acid and the base. The Lewis acid-base reaction between ammonia and acetic acid is represented in Figure 6.1a. In it, the lone pair on ammonia is used to form a covalent bond to a hydrogen atom on the acetic acid. Ammonia contains the lone pair, so it is the base, and acetic acid accepts the lone pair, so it is the acid. This very broad classification allows us to treat many reactions as acid-base reactions. However, the reaction in Figure 6.1 can also be viewed as a proton transfer from the acid to the base. Although proton transfer reactions can be viewed as Lewis acid-base reactions, a different acid-base theory was developed for this very important branch of chemistry.†

In Brønsted-Lowery or simply Brønsted theory, an acid is a proton donor and a base is a proton acceptor. Acetic acid has a proton that it can transfer, so it is an acid, while ammonia can accept a proton, so it is a base. The loss of a proton converts the acid into its **conjugate base**, and the gain of the proton converts the base into its **conjugate acid** (Figure 6.1b). An acid and a base differ by one proton only and are said to be a **conjugate acid-base pair**. *The only reactants and products present in a Brønsted acid-base reaction are an acid, a base, and their conjugate base and acid.* In this chapter, we examine the concentrations of reactants and products in aqueous solutions of Brønsted acids and bases.

#### THE OBJECTIVES OF THIS CHAPTER ARE TO:

- explain how water is involved in aqueous acid-base chemistry;
- define pH and pOH and demonstrate their use;
- show how to calculate the concentrations of all species present in an equilibrium mixture of an acid and a base; and
- describe the solution of acids with more than one proton.

\* Coordinate covalent bonds are covalent bonds in which both bonding electrons come from the same atom – the base in a Lewis acid-base reaction.

† Both Brønsted and Lewis theories were introduced in detail in Chapter 12 of CAMS.

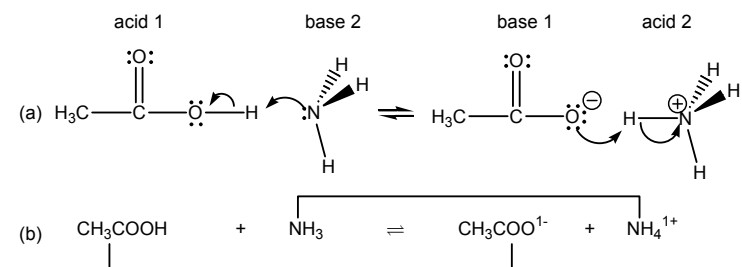

**Figure 6.1** Acid-base reaction between acetic acid and ammonia  
(a) Lewis formalism in which the lone pair on N become an N-H bond.  
(b) Brønsted formalism in which a proton is transferred from the acid to the base. The conjugate acid-base pairs ( $\text{CH}_3\text{COOH}/\text{CH}_3\text{COO}^{1-}$  and  $\text{NH}_4^{1+}/\text{NH}_3$ ) are identified by brackets.

## 6.1 AUTOIONIZATION OF WATER

Aqueous acid-base chemistry is the focus of this chapter, and water plays an important role in that chemistry because in addition to being the solvent, water is also an acid and a base; that is, water is **amphiprotic**. In fact, the acidity or basicity of an aqueous solution is defined by the extent to which water reacts to produce its conjugate acid,  $\text{H}_3\text{O}^{1+}$ , or its conjugate base,  $\text{OH}^{1-}$ , respectively. Because it is amphiprotic, water can react with itself in a process called **autoionization**.



The equilibrium constant expression for Reaction 6.1 is known as the **ion product constant of water** and given the symbol  $K_w$ . Water is the solvent and considered to be a pure liquid, so its activity is unity and the equilibrium constant is.

$$K_w = [\text{H}_3\text{O}^{1+}][\text{OH}^{1-}] = 1.0 \times 10^{-14} \text{ at } 25^\circ\text{C} \quad \text{Eq. 6.1}$$

*The  $K_w$  expression must be obeyed in all aqueous solutions, but equilibrium constants are functions of temperature, so  $K_w = 1.0 \times 10^{-14}$  only at  $25^\circ\text{C}$ .* If no temperature is given, assume a temperature of  $25^\circ\text{C}$  and a  $K_w$  of  $1.0 \times 10^{-14}$

Reaction 6.1 indicates a 1:1 stoichiometry between  $\text{H}_3\text{O}^{1+}$  and  $\text{OH}^{1-}$ , so their concentrations are equal in pure water. Solutions in which  $[\text{H}_3\text{O}^{1+}] = [\text{OH}^{1-}]$  are said to be **neutral** because they are neither acidic nor basic. Pure water is neutral,<sup>†</sup> but when an acid is added, a proton transfer from the acid to water increases the hydronium ion concentration, which makes the solution acidic. Equation 6.1 indicates that an increase in  $[\text{H}_3\text{O}^{1+}]$  must be accompanied by a decrease in  $[\text{OH}^{1-}]$ , so  $[\text{H}_3\text{O}^{1+}] > [\text{OH}^{1-}]$  in **acidic** solutions. Similarly, adding a base to water results in a proton transfer from water to the base, which produces  $\text{OH}^{1-}$  and makes the solution basic. Consequently,  $[\text{OH}^{1-}] > [\text{H}_3\text{O}^{1+}]$  in **basic** solutions. As demonstrated in Example 6.1, the hydronium and hydroxide ion concentrations can be determined from one another with  $K_w$ .

\* The remainder of the text deals with aqueous chemistry, so water is always considered to be a pure liquid and ions are only present when dissolved in water. Therefore, we will drop the (l) tag for water and the (aq) tags for ions. However, other neutral species can be solid, liquid, gas, or aqueous, so the phase tag will be used with them.

† Tap water is usually slightly acidic due to dissolved  $\text{CO}_2$ , which reacts with water to produce carbonic acid.

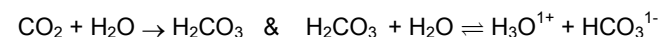

Boiling the water drives off the  $\text{CO}_2$  and makes the water neutral.

### Example 6.1

a) What are the hydronium and hydroxide ion concentrations in water at  $25^\circ\text{C}$ ?

Let  $x = [\text{H}_3\text{O}^{1+}] = [\text{OH}^{1-}]$  and substitute into Equation 6.1 to obtain

$$[\text{H}_3\text{O}^{1+}][\text{OH}^{1-}] = (x)(x) = x^2 = 1.0 \times 10^{-14}$$

$$x = \sqrt{K_w} = \sqrt{1.0 \times 10^{-14}} = 1.0 \times 10^{-7} \text{ M} = [\text{OH}^{1-}] = [\text{H}_3\text{O}^{1+}]$$

$[\text{OH}^{1-}] = [\text{H}_3\text{O}^{1+}] = 1.0 \times 10^{-7} \text{ M}$  at  $25^\circ\text{C}$  in a neutral aqueous solution.

- b) HCl is added to water until  $[\text{H}_3\text{O}^{1+}] = 0.042 \text{ M}$ . What is the concentration of the hydroxide ion in the resulting solution at  $25^\circ\text{C}$ ?

Solving Equation 6.1 for the hydroxide ion concentration, we obtain

$$[\text{OH}^{1-}] = \frac{K_w}{[\text{H}_3\text{O}^{1+}]} = \frac{1.0 \times 10^{-14}}{0.042} = 2.4 \times 10^{-13} \text{ M}$$

- c) What is  $[\text{H}_3\text{O}^{1+}]$  in a solution that is  $0.50 \text{ M}$  in hydroxide ion at  $25^\circ\text{C}$ ?

Solving Equation 6.1 for the hydronium ion concentration, we obtain

$$[\text{H}_3\text{O}^{1+}] = \frac{K_w}{[\text{OH}^{1-}]} = \frac{1.0 \times 10^{-14}}{0.50} = 2.0 \times 10^{-14} \text{ M}$$

## 6.2 THE p-SCALE

The hydroxide and hydronium ion concentrations are important characteristics of the solution even at very low concentrations, but negative exponentials are usually avoided in discussions of these small concentrations by converting them to the p-scale. The **p-scale** is the negative base-10 logarithm of the number.

$$\text{pX} = -\log X \quad \text{Eq. 6.2}$$

Thus,  $\text{pH} = -\log [\text{H}_3\text{O}^{1+}]$  and  $\text{pOH} = -\log [\text{OH}^{1-}]$ . Taking the antilogarithm of both sides yields Equation 6.3, which allows the value of X to be determined from its pX.

$$X = 10^{-\text{pX}} \quad \text{Eq. 6.3}$$

For example,  $[\text{H}_3\text{O}^{1+}] = 10^{-\text{pH}}$  and  $[\text{OH}^{1-}] = 10^{-\text{pOH}}$ . The digits to the left of the decimal in a value of X determined from its pX with Equation 6.3 are used for the exponent of 10, so *only those digits to the right of the decimal in a pX are significant digits*. For example, if  $\text{pH} = 12.65$  then  $[\text{H}_3\text{O}^{1+}] = 10^{-\text{pH}} = 10^{-12.65} = 2.2 \times 10^{-13} \text{ M}$ , which is good to only two significant figures because only two of the digits of the pH are to the right of the decimal.

### Example 6.2

What are the pH and pOH of the solutions discussed in Example 6.1?

- a)  $[\text{H}_3\text{O}^{1+}] = [\text{OH}^{1-}] = 1.0 \times 10^{-7} \text{ M}$

$$\text{pH} = \text{pOH} = -\log (1.0 \times 10^{-7}) = 7.00$$

The pH of a neutral solution is 7.00 at  $25^\circ\text{C}$ .

- b)  $[\text{H}_3\text{O}^{1+}] = 0.042 \text{ M}$  and  $[\text{OH}^{1-}] = 2.4 \times 10^{-13} \text{ M}$   
 $\text{pH} = -\log(0.042) = 1.38$  and  $\text{pOH} = -\log(2.4 \times 10^{-13}) = 12.62$   
 $\text{pH} < 7$ ,  $[\text{H}_3\text{O}^{1+}] > [\text{OH}^{1-}]$ , and the solution is acidic.
- c)  $[\text{H}_3\text{O}^{1+}] = 2.0 \times 10^{-14}$  and  $[\text{OH}^{1-}] = 0.50$   
 $\text{pH} = -\log(2.0 \times 10^{-14}) = 13.70$  and  $\text{pOH} = -\log(0.50) = 0.30$   
 $\text{pH} > 7$ ,  $[\text{OH}^{1-}] > [\text{H}_3\text{O}^{1+}]$ , and it is a basic solution.

As shown in Figure 6.2, an acidic solution is characterized by a pH of less than seven, while a pH greater than seven implies a basic solution. In more general terms, as the pH of a solution decreases, it becomes more acidic (less basic) and, as the pH increases, the solution becomes more basic (less acidic). Note that the pH range for most aqueous solutions is 0 to 14, but pH values greater than 14 and less than 0 result when  $[\text{H}_3\text{O}^{1+}]$  or  $[\text{OH}^{1-}] > 1 \text{ M}$ . For example, the pH of a solution that is 2 M in  $\text{H}_3\text{O}^{1+}$  is  $-\log 2 = -0.3$ , and the pH of 2 M  $\text{OH}^{1-}$  is  $14.0 - (-0.3) = 14.3$ .

The p-scale can also be applied to equilibrium constants. Thus, if we take the negative logarithm of both sides of Equation 6.1, we obtain

$$\text{pK}_w = \text{pH} + \text{pOH} = 14.00 \text{ at } 25^\circ\text{C} \quad \text{Eq. 6.4}$$

As is true for all equilibrium constants,  $K_w$  varies with temperature, and  $\text{pK}_w$  is equal to 14.00 at  $25^\circ\text{C}$  only. The value of  $\text{pK}_w$  at several temperatures is given in Table 6.1. If the pH or the pOH is known, the other can be determined by subtraction of the known quantity from  $\text{pK}_w$ . For example, consider Example 6.2c. Once the pOH of the solution had been determined to be 0.30, the pH could have been determined as  $\text{pH} = 14.00 - 0.30 = 13.70$ .

### Example 6.3

What are  $[\text{H}_3\text{O}^{1+}]$  and  $[\text{OH}^{1-}]$  in a solution with a pH of 8.62 at  $25^\circ\text{C}$ ?

We apply Equation 6.3 to determine the hydronium ion concentration.

$$[\text{H}_3\text{O}^{1+}] = 10^{-\text{pH}} = 10^{-8.62} = 2.4 \times 10^{-9} \text{ M}$$

We can now determine the hydroxide ion concentration by using Equation 6.1:

$$[\text{OH}^{1-}] = \frac{K_w}{[\text{H}_3\text{O}^{1+}]} = \frac{1.0 \times 10^{-14}}{2.4 \times 10^{-9}} = 4.2 \times 10^{-6} \text{ M}$$

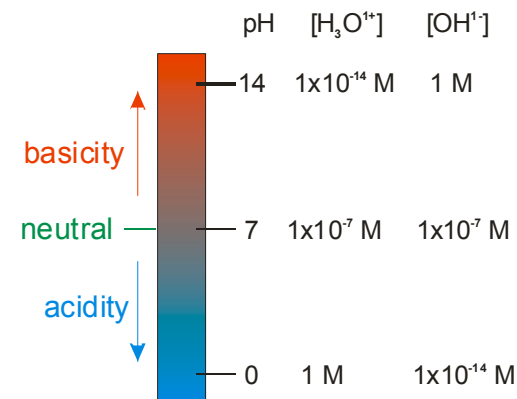

**Figure 6.2 Relationship between pH, acidity and basicity**  
 An increase in pH implies a decrease in the acidity of the solution or an increase in its basicity.

**Table 6.1**  $\text{pK}_w$  at various temperatures.

T ( $^\circ\text{C}$ )	$\text{pK}_w$	$K_w$
0	14.94	$1.15 \times 10^{-15}$
25	14.00	$1.00 \times 10^{-14}$
50	13.28	$5.25 \times 10^{-14}$
75	12.71	$1.95 \times 10^{-13}$
100	12.26	$5.50 \times 10^{-13}$

Or, use Equation 6.4 to get the pOH and then Equation 6.3 to get  $[\text{OH}^-]$

$$\text{pOH} = \text{p}K_w - \text{pH} = 14.00 - 8.62 = 5.38; \quad [\text{OH}^-] = 10^{-\text{pOH}} = 10^{-5.38} = 4.2 \times 10^{-6} \text{ M}$$

The advantage to the second method is that it does not rely on a previous calculation. Thus, the hydroxide concentration could be correct even if a mistake is made in the calculation of the hydronium ion concentration.

### Example 6.4

**What are the pH,  $[\text{H}_3\text{O}^{1+}]$ , and  $[\text{OH}^-]$  in pure water at 75 °C?**

Determine pH and pOH from Equation 6.4 by using the value of  $\text{p}K_w$  at 75 °C given in Table 6.1 and the fact that  $\text{pH} = \text{pOH} = x$  in pure water.

$$\text{p}K_w = 12.71 = \text{pH} + \text{pOH} = 2x; \quad x = \text{pH} = \text{pOH} = \frac{1}{2}(12.71) = 6.35$$

Use Equation 6.3 and the pH and pOH values determined above to find the concentrations.

$$[\text{H}_3\text{O}^{1+}] = 10^{-\text{pH}} = [\text{OH}^-] = 10^{-\text{pOH}} = 10^{-6.35} = 4.5 \times 10^{-7} \text{ M}$$

Thus, the hydronium and hydroxide ion concentrations are 4.5 times greater at 75 °C than at 25 °C.

The pH of an aqueous solution changes when an acid is added because the acid reacts with water. The equilibrium constant for the reaction is called the **acid dissociation** or **acid ionization constant**\* and given the symbol  $K_a$ . Consider the chemical equation and acid dissociation constant for the addition of a generic acid HA to water

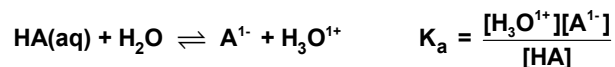

Acids are classified as either strong or weak based upon the extent of the above reaction. Strong acids are those for which  $K_a \gg 1$ , and weak acids are those for which  $K_a \ll 1$ .

## 6.3 STRONG ACIDS

The commonly encountered strong acids are perchloric acid ( $\text{HClO}_4$ ), the hydrohalic acids (HI, HBr and HCl), sulfuric acid ( $\text{H}_2\text{SO}_4$ ) and nitric acid ( $\text{HNO}_3$ ). Essentially all of a strong acid reacts with water to produce hydronium ion and the conjugate base of the strong acid. Indeed, the acid dissociation constants of weak acids are very large because the equilibrium concentration of the acid is nearly zero. Consider the following reaction table for the reaction between  $\text{H}_2\text{O}$  and HCl, a typical strong acid.

### PRACTICE EXAMPLE 6.1

a) The pH of a sample of lemon juice is found to be 2.32. What are the hydronium and hydroxide ion concentrations?

$$[\text{H}_3\text{O}^{1+}] =$$

$$\text{pOH} =$$

$$[\text{OH}^-] =$$

b) The hydroxide ion concentration in a bottle of household ammonia is 0.0083 M. What are the pH, pOH, and hydronium ion concentration?

$$\text{pH} =$$

$$\text{pOH} =$$

$$[\text{H}_3\text{O}^{1+}] =$$

\* In Arrhenius acid-base theory acids dissociate or ionize in water not react with it. For example,  $\text{HF} \rightarrow \text{H}^{1+} + \text{F}^{1-}$ . Although, acids react with water in Brønsted theory, the terms 'acid dissociation' and 'acid ionization' are still in common use. Thus,  $K_a$  is commonly referred to as the acid dissociation or acid ionization constant of the acid.

	$\text{HCl(aq)} + \text{H}_2\text{O} \rightarrow \text{H}_3\text{O}^{1+}(\text{aq}) + \text{Cl}^{1-}(\text{aq})$		
initial	$c_0$	0	0
$\Delta$	$-c_0$	$+c_0$	$+c_0$
eq	$\sim 0$	$c_0$	$c_0$

$c_0$  is the original or *makeup* concentration of the acid. The concentration given on a bottle of acid is the makeup concentration, not the concentration of acid molecules at equilibrium. The concentration of hydronium ions in a solution of a strong monoprotic acid equals the makeup concentration. Thus, a bottle labeled 0.10 M HCl is 0.10 M in  $\text{H}_3\text{O}^{1+}$  and 0.10 M in  $\text{Cl}^{1-}$ , but it contains essentially no HCl molecules.

### Example 6.5

**What is the pH of a 0.16-M solution of hydrochloric acid?**

HCl is a strong acid, so

$$[\text{H}_3\text{O}^{1+}] = c_0 = 0.16 \text{ M, and } \text{pH} = -\log(0.16) = 0.80$$

## 6.4 WEAK ACIDS

Weak acids react to only a small extent with water, so the composition of their aqueous equilibria depends upon both their makeup concentration ( $c_0$ ) and their dissociation constant ( $K_a$ ). Water is again considered the solvent and treated as a pure liquid, so its activity does not appear in the reaction table. The initial concentration of the conjugate base ( $\text{A}^{1-}$ ) is zero. The initial concentration of the hydronium ion in pure water is  $1.0 \times 10^{-7}$  M, but we enter zero because  $10^{-7}$  M is negligibly small and does not impact the final hydronium ion concentration except for the most dilute acid solutions. The extent of reaction is unknown ( $K_a \ll 1$ ), so the  $\Delta$  line contains the unknown. Thus, the reaction table for the 'dissociation' of a generic weak acid HA in water has the following form:

	$\text{HA(aq)} + \text{H}_2\text{O} \rightleftharpoons \text{A}^{1-} + \text{H}_3\text{O}^{1+}$		
initial	$c_0$	0	0
$\Delta$	$-x$	$+x$	$+x$
eq	$c_0 - x$	$x$	$x$

The equilibrium constant expression can then be written as follows:

$$K_a = \frac{[\text{A}^{1-}][\text{H}_3\text{O}^{1+}]}{[\text{HA}]} = \frac{(x)(x)}{c_0 - x} *$$

\* Selected  $K_a$ 's can be found in Appendix C.

Thus, we must solve the following quadratic expression to determine the composition of the equilibrium mixture:

$$K_a = \frac{x^2}{c_0 - x} \quad \text{Eq. 6.5}$$

Equation 6.5 is a quadratic equation,\* so it has two solutions ( $\pm$  square root term). However, the restriction that  $0 < x < c_0$  will be obeyed by only one solution.

\* **Quadratic equations** are solved by rearranging them so they have the following form:

$$ax^2 + bx + c = 0$$

The two solutions are then given by the following quadratic formula:

$$x = \frac{-b \pm \sqrt{b^2 - 4ac}}{2a}$$

The quadratic formula can also be found in the table of Fundamental Constants on the inside of the back cover.

### Example 6.6

**What is the pH of 0.088 M HF?**

Setup the reaction table and get the value of  $K_a$  from Appendix C.

	$\text{HF(aq)} + \text{H}_2\text{O(l)} \rightleftharpoons \text{F}^- + \text{H}_3\text{O}^{1+}$	$K_a = 7.2 \times 10^{-4}$
<b>initial</b>	<b>0.088</b> <b>0</b> <b>0</b> <b>M</b>	
<b><math>\Delta</math></b>	<b>-x</b> <b>+x</b> <b>+x</b> <b>M</b>	
<b>eq</b>	<b>0.088 - x</b> <b>x</b> <b>x</b> <b>M</b>	

Setup the equilibrium constant expression (Equation 6.5)

$$K_a = \frac{[\text{F}^-][\text{H}_3\text{O}^{1+}]}{[\text{HF}]} = \frac{x^2}{0.088 - x} = 7.2 \times 10^{-4}$$

Multiply both sides by  $0.088 - x$ :  $x^2 = (7.2 \times 10^{-4})(0.088) - 7.2 \times 10^{-4}x$

Get in the form of a quadratic equation\*:  $x^2 + 7.2 \times 10^{-4}x - (7.2 \times 10^{-4})(0.088) = 0$

Use the quadratic formula to solve:  $x = \frac{-7.2 \times 10^{-4} \pm \sqrt{(7.2 \times 10^{-4})^2 + 4(7.2 \times 10^{-4})(0.088)}}{2}$

Discard the negative solution because  $x$  is a concentration and cannot be negative.

$$x = 7.6 \times 10^{-3} \text{ M} = [\text{H}_3\text{O}^{1+}] = [\text{F}^-] \quad \& \quad [\text{HF}] = 0.088 - 0.0076 = 0.080 \text{ M}$$

Check your answer by calculating  $K_a$  with the answers:  $K_a = \frac{(7.6 \times 10^{-3})^2}{0.080} = 7.2 \times 10^{-4}$  ✓

$$\text{pH} = -\log [\text{H}_3\text{O}^{1+}] = -\log (7.6 \times 10^{-3}) = 2.12$$

If the extent of reaction is very small, the following approximation, known as the '**5% rule**', can be used to avoid solving a quadratic equation:

If less than 5% of a weak acid reacts, *i.e.*, if  $x/c_0 < 0.05$ , then  $x$  can be assumed to be negligible in the subtraction from  $c_0$ ; that is,  $c_0 - x \sim c_0$ .

Rewriting the expression for  $K_a$  for an acid obeying the 5% rule, we obtain the following:

$$K_a = \frac{(x)(x)}{c_0 - x} \sim \frac{(x)(x)}{c_0} = \frac{x^2}{c_0}$$

Solving for  $x$ , we obtain the hydronium ion concentration and the conjugate base concentration in solutions of weak acids that dissociate less than 5% in water,

$$[\text{H}_3\text{O}^{1+}] = [\text{conjugate base}] = \sqrt{K_a c_0} \quad \text{Eq. 6.6}$$

The concentrations of the equilibrium species in a solution of  $c_0$  M HA are the following if the acid obeys the 5% rule:

$$[\text{HA}] = c_0 \quad [\text{A}^{1-}] = [\text{H}_3\text{O}^{1+}] = \sqrt{K_a c_0}$$

Although the use of Equation 6.6 is quick and greatly simplifies the algebra, care must be exercised in its use. Consider that the application of Equation 6.6 to the 0.088-M solution of HF presented in Example 6.6 yields  $[\text{HF}] = 0.088\text{M}$  and  $[\text{F}^{1-}] = [\text{H}_3\text{O}^{1+}] = \sqrt{(7.2 \times 10^{-4})(0.088)} = 8.0 \times 10^{-3}\text{M}$ , which differs from the concentrations obtained using the quadratic formula. The reason for the discrepancy is that  $x/c_0 = 0.086$  or 8.6%. More than 5% of the acid dissociates, so the approximation is not valid. *Whenever you use Equation 6.6 you must check your answer to make sure that  $x$  is less than 5% of  $c_0$ .*

There are three variables in equilibria involving weak acid solutions: the hydronium ion and/or conjugate base concentration ( $x$ ); the initial or makeup concentration of the acid ( $c_0$ ); and the  $K_a$  of the weak acid, so there are three types of problems involving weak acid solutions in which two of the variables are given and the third is to be determined.

### Example 6.7

**What is the pH of a 0.10-M solution of acetic acid.**

We are given  $c_0 = 0.10\text{M}$  and that the acid is acetic acid, which allows us to use Appendix C to determine that  $K_a = 1.8 \times 10^{-5}$ . The reaction table for the dissociation is

	$\text{CH}_3\text{COOH}(\text{aq}) + \text{H}_2\text{O} \rightleftharpoons \text{CH}_3\text{COO}^{1-} + \text{H}_3\text{O}^{1+}$		
initial	0.10	0	0
$\Delta$	- $x$	+ $x$	+ $x$
eq.	0.10 - $x$	$x$	$x$

Assume that  $x$  is negligible in the subtraction in the denominator  $K_a$  expression to obtain

$$1.8 \times 10^{-5} = \frac{(x)(x)}{(0.10 - x)} \sim \frac{x^2}{0.10}$$

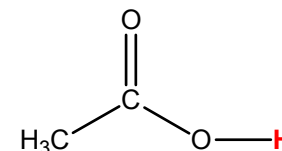

### Acetic acid

Acetic acid is a carboxylic acid ( $-\text{COOH}$  group). It is responsible for the tart taste and pungent odor of vinegar, which is a  $\sim 4.5\%$  solution of acetic acid. Acetic acid is also used in the manufacture of acetates and pharmaceuticals. The acidic proton is shown in red.

### PRACTICE EXAMPLE 6.2

**What is the pH of a 0.080-M solution of ammonium nitrate?**

$K_a$  of  $\text{NH}_4^{1+} =$  \_\_\_\_\_ from Appendix C

$K_a$  reaction: \_\_\_\_\_

if  $[\text{NH}_3] = [\text{H}_3\text{O}^{1+}] = x$ , then  $[\text{NH}_4^{1+}] =$  \_\_\_\_\_

$K_a$  expression in terms of  $x$

$K_a =$

$[\text{H}_3\text{O}^{1+}] = x =$  \_\_\_\_\_  $=$  \_\_\_\_\_ M

Is approximation acceptable? \_\_\_\_

pH =

Solve for the hydronium ion concentration, x.

$$[\text{H}_3\text{O}^{1+}] = \sqrt{K_a c_o} = \sqrt{(1.8 \times 10^{-5})(0.10)} = \sqrt{1.8 \times 10^{-6}} = 0.0013 \text{ M}$$

Check the approximation:  $x/c_o = 0.0013/0.10 = 0.013 < 0.05$  ✓

The pH of the solution is  $\text{pH} = -\log [\text{H}_3\text{O}^{1+}] = -\log (0.0013) = 2.87$

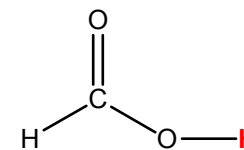

### Formic acid

Formic acid is the simplest carboxylic acid. It is a colorless liquid that is widely used in the chemical dyeing and tanning industries. It can also be found in the poisons of some insects and nettles. The acidic proton is shown in red.

### Example 6.8

How many grams of formic acid are required to prepare 500.0 mL of a pH = 2.447 solution?  $K_a = 1.79 \times 10^{-4}$

We are asked for  $c_o$  given the  $K_a$  and the pH of the solution (x).

1) Convert the pH to the concentrations

$$[\text{H}_3\text{O}^{1+}] = [\text{HCOO}^{1-}] = 10^{-\text{pH}} = 10^{-2.447} = 0.00357 \text{ M}$$

2) Setup the reaction table

	$\text{HCOOH(aq)}$	$+$	$\text{H}_2\text{O}$	$\rightleftharpoons$	$\text{HCOO}^{1-}$	$+$	$\text{H}_3\text{O}^{1+}$
initial	$c_o$				0		0
$\Delta$	-0.00357				+0.00357		+0.00357
eq.	$c_o - 0.00357$				+0.00357		+0.00357

3) Substitute the known quantities into  $K_a$

$$K_a = \frac{(0.00357)^2}{c_o - 0.00357} = 1.79 \times 10^{-4}$$

Note that Equation 6.6 should be used only when the amount reacting is to be determined because it allows us to reduce the algebra. However, there is no quadratic equation required in the determination of either  $K_a$  or  $c_o$ , so there is no reason to use the approximation.

4) Solve for  $c_o$

$$c_o = 0.00357 + \frac{(0.00357)^2}{1.79 \times 10^{-4}} = 0.0748 \text{ M}$$

If Equation 6.6 had been used,  $c_o = 0.0712 \text{ M}$  and  $x/c_o = 0.0501 > 0.05$ .

5) Use the volume and molarity of the solution and the molar mass of  $\text{HCHO}_2$  to determine the mass of  $\text{HCHO}_2$ .

$$0.5000 \text{ L} \times \frac{0.0748 \text{ mol}}{\text{L}} \times \frac{46.03 \text{ g}}{\text{mol}} = 1.72 \text{ g}$$

### PRACTICE EXAMPLE 6.3

What initial concentration of a  $\text{KHSO}_4$  solution would be required to make a pH = 2.00 solution?

$K_a =$

$K_a$  reaction:

$[\text{H}_3\text{O}^{1+}] =$

$[\text{SO}_4^{2-}] =$

$[\text{HSO}_4^{1-}]$  in terms of  $c_o =$

$K_a$  expression in terms of unknown  $c_o$ :

$K_a =$

Solve for  $c_o$

**Example 6.9**

What is the  $K_a$  of iodic acid ( $\text{HIO}_3$ ) if the pH of a 0.140-M solution is 1.040?

We are given the makeup and equilibrium concentrations and are asked for  $K_a$ . First convert the pH to the equilibrium concentrations:

$$x = [\text{IO}_3^{1-}] = [\text{H}_3\text{O}^{1+}] = 10^{-\text{pH}} = 10^{-1.040} = 0.0912 \text{ M}$$

then setup the reaction table.

	$\text{HIO}_3(\text{aq}) + \text{H}_2\text{O} \rightleftharpoons$	$\text{IO}_3^{1-}$	+	$\text{H}_3\text{O}^{1+}$	
initial	0.140	0		0	M
$\Delta$	-0.0912	+0.0912		+0.0912	M
eq.	0.049	+0.0912		+0.0912	M

Substitute these values into the  $K_a$  expression:

$$K_a = \frac{[\text{IO}_3^{1-}][\text{H}_3\text{O}^{1+}]}{[\text{HIO}_3]} = \frac{(0.0912)^2}{0.049} = 0.17$$

The fraction of a weak acid that reacts with or dissociates in water is  $x/c_o$ , where  $x$  is the equilibrium concentration of the hydronium ion (or conjugate base). If the acid ionization is negligible ( $< 5\%$ ), we can substitute,  $\sqrt{K_a c_o}$  for  $x$  to obtain

$$\text{fraction of acid reacting} = \frac{x}{c_o} = \frac{\sqrt{K_a c_o}}{c_o} = \sqrt{\frac{K_a c_o}{c_o^2}} = \sqrt{\frac{K_a}{c_o}}$$

Multiplying the preceding fraction by 100 we obtain Equation 6.7 for the percent ionization.

$$\text{percent ionization of a weak acid} = \sqrt{\frac{K_a}{c_o}} \times 100\% \quad \text{Eq. 6.7}$$

Table 6.2 shows the percent ionization of several solutions of nitrous acid, acetic acid and hypochlorous acid solutions as determined by Equation 6.7. Note that for most common concentrations ( $0.010 \text{ M} < c_o < 1.0 \text{ M}$ ), acids with  $K_a < 10^{-5}$  obey the 5% rule, but more dilute and/or stronger acids probably will not.

**Example 6.10**

a) What are the percent ionization and pH of 0.026 M HCN ( $K_a = 4.0 \times 10^{-10}$ )?

$$\text{Equation 6.7 yields } \% = \sqrt{\frac{4.0 \times 10^{-10}}{0.026}} \times 100\% = 0.012\%$$

The above is well below 5% ✓, so Equation 6.6 is valid and can be used to determine the

**Table 6.2** Percent ionization of nitrous, acetic and hypochlorous acids as a function of their concentrations.

Molarity	$\text{HNO}_2$ $K_a = 4.0 \times 10^{-4}$	$\text{CH}_3\text{COOH}$ $K_a = 1.8 \times 10^{-5}$	$\text{HOCl}$ $K_a = 3.5 \times 10^{-8}$
1.0	2.0	0.42%	0.019%
0.10	6.1% <sup>†</sup>	1.3%	0.059%
0.010	18% <sup>†</sup>	4.2%*	0.19%
0.0001	83% <sup>†</sup>	34% <sup>†</sup>	1.9%

\* Note that the percent is close to but less than 5% in 0.01 M acetic acid. We conclude that the dissociation of any acid that is weaker than acetic acid and whose concentration is greater than 0.01 M can be assumed to be negligible.

† Equation 6.7 cannot be used because over 5% reacts. Indeed, the tabulated value was obtained by calculating  $x$  with the quadratic equation.

hydronium ion concentration and the pH:

$$[\text{H}_3\text{O}^{1+}] = \sqrt{(4.0 \times 10^{-10})(0.026)} = 3.2 \times 10^{-6} \text{ M}; \text{pH} = -\log(3.2 \times 10^{-6}) = 5.49$$

b) What are the percent ionization and pH of 0.026 M HF ( $K_a = 7.2 \times 10^{-4}$ )?

Equation 6.7 yields  $\% = \sqrt{\frac{7.2 \times 10^{-4}}{0.026}} \times 100\% = 17\%$ , which exceeds 5%. Thus, we cannot

assume  $x$  is negligible. The reaction table is

	HF	+	H <sub>2</sub> O	⇌	F <sup>1-</sup>	+	H <sub>3</sub> O <sup>1+</sup>
initial	0.026				0		0
Δ	-x				+x		+x
eq.	0.026-x				x		x

SETUP THE  $K_a$  EXPRESSION:  $7.2 \times 10^{-4} = \frac{x^2}{(0.026 - x)}$

Eliminate the denominator:  $(7.2 \times 10^{-4})(0.026) - 7.2 \times 10^{-4} x = x^2$

Rearrange to the quadratic form:  $x^2 + 7.2 \times 10^{-4} x - 1.87 \times 10^{-5} = 0$

Use the quadratic formula to solve for  $x = [\text{H}_3\text{O}^{1+}]$ .

$$[\text{H}_3\text{O}^{1+}] = \frac{-7.2 \times 10^{-4} + \sqrt{(7.2 \times 10^{-4})^2 - 4(1)(-1.87 \times 10^{-5})}}{2} = 4.0 \times 10^{-3} \text{ M}$$

Determine the percent ionization of the acid and the pH of the solution

$$\% = \frac{0.0040 \text{ M}}{0.026 \text{ M}} \times 100\% = 15\% \quad \& \quad \text{pH} = -\log(4.0 \times 10^{-3}) = 2.40$$

## 6.5 POLYPROTIC ACIDS

**Polyprotic acids\*** have two or more acidic protons that they lose one at a time. Removal of a proton strengthens the remaining O–H bonds, which makes each subsequent acid weaker. Consider the step-wise dissociation of the triprotic acid  $\text{H}_3\text{PO}_4$ .

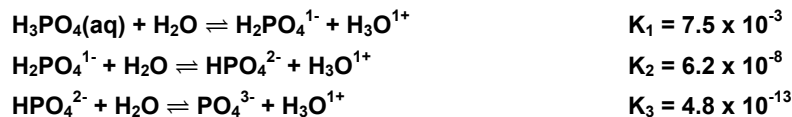

Each  $K_a$  is smaller by a factor of  $\sim 10^5$ , which means that the amount of any species formed in one dissociation is unaffected by subsequent reactions. Consequently, the *hydronium ion concentration in most polyprotic acids can be determined from the first ionization in the same way that it is determined for a monoprotic acid because the amount of hydronium ion produced after the first ionization is negligible.*

\* Polyprotic is a general term meaning many protons. Most polyprotic acids have two or three protons. Those with two are said to be **diprotic** ( $\text{H}_2\text{A}$ ) and those with three are **triprotic** ( $\text{H}_3\text{A}$ ).

**Example 6.11**

What are the concentrations of all species present in 0.10 M H<sub>2</sub>S?

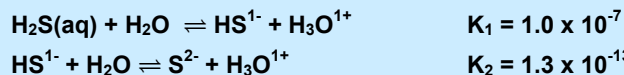

1) Create the reaction table for the first equilibrium

	$\text{H}_2\text{S}(\text{aq}) + \text{H}_2\text{O} \rightleftharpoons \text{HS}^{1-} + \text{H}_3\text{O}^{1+}$		
initial	0.10	0	0
$\Delta$	-x	+x	+x
eq.	0.10 - x	+x	+x

2) Assume that  $0.10 - x = 0.10$  and substitute the eq line into the  $K_1$  expression

$$1.0 \times 10^{-7} = \frac{x^2}{0.10} \Rightarrow x = [\text{H}_3\text{O}^{1+}] = [\text{HS}^{1-}] = \sqrt{(1.0 \times 10^{-7})(0.1)} = 1.0 \times 10^{-4} \text{ M}$$

$$1.0 \times 10^{-4} / 0.10 = 1.0 \times 10^{-3} < 0.05, \text{ so approximation is valid. } \checkmark$$

3) The reaction table for the second equilibrium is

	$\text{HS}^{1-} + \text{H}_2\text{O}(\text{l}) \rightleftharpoons \text{S}^{2-} + \text{H}_3\text{O}^{1+} \quad K_2 = 1.3 \times 10^{-13}$		
initial	$1.0 \times 10^{-4}$	0	$1.0 \times 10^{-4}$
$\Delta$	-y	+y	+y
eq.	$1.0 \times 10^{-4} - y$	+y	$1.0 \times 10^{-4} + y$

4)  $K_2$  is very small, so y is probably negligible in both the addition and the subtraction,

$$1.0 \times 10^{-4} \pm y = 1.0 \times 10^{-4} \text{ M} = [\text{H}_3\text{O}^{1+}] = [\text{HS}^{1-}], \text{ so}$$

$$y = \frac{[\text{S}^{2-}][1.0 \times 10^{-4}]}{[1.0 \times 10^{-4}]} = 1.3 \times 10^{-13} \text{ M} = \boxed{K_2 = [\text{S}^{2-}]}$$

$$1.3 \times 10^{-13} \ll 1.0 \times 10^{-4}, \text{ so approximation is valid. } \checkmark$$

As shown in Example 6.11,

The concentration of the ion produced in the second ionization of a weak polyprotic acid equals the second ionization constant ( $K_2$ ) of the acid.

For example,  $K_2 = 6.2 \times 10^{-8}$  for  $\text{H}_3\text{PO}_4$ , so  $[\text{HPO}_4^{2-}] = 6.2 \times 10^{-8} \text{ M}$  in a phosphoric acid solution and is independent of the concentration of phosphoric acid so long  $[\text{H}_3\text{O}^{1+}] \gg K_2$ .

**PRACTICE EXAMPLE 6.4**

What are the pH, and the concentrations of all carbon containing species in 0.18-M H<sub>2</sub>CO<sub>3</sub>?

Reaction table and equilibrium constant from Appendix C for the first dissociation:

Reaction	_____			$K_1 =$
in				
$\Delta$				
eq				

$$[\text{H}_3\text{O}^{1+}] = \text{_____} = \text{_____} \text{ M}$$

$$\text{pH} = \text{_____}$$

$$[\text{HCO}_3^{1-}] = \text{_____} \text{ M}$$

$$[\text{H}_2\text{CO}_3] = \text{_____} \text{ M}$$

Reaction table and equilibrium constant from Appendix C for the second dissociation:

Reaction	_____			$K_2 =$
in				
$\Delta$				
eq				

$$[\text{CO}_3^{2-}] = \text{_____} \text{ M}$$

### Example 6.12

What are the  $\text{H}_3\text{O}^{1+}$ ,  $\text{HSO}_4^{1-}$ , and  $\text{SO}_4^{2-}$  concentrations in 0.10 M sulfuric acid?

Sulfuric acid is a unique polyprotic acid because  $\text{H}_2\text{SO}_4$  is a strong acid as the first ionization is complete.

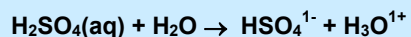

initial	0.10	0	0	M
$\Delta$	-0.10	+0.10	+0.10	M
eq	~0	0.10	0.10	M

$\text{HSO}_4^{1-}$  is a weak acid, so its dissociation reaction must be considered next. The initial concentrations of the  $\text{HSO}_4^{1-}$  and  $\text{H}_3\text{O}^{1+}$  ions are 0.10 M due to the above.

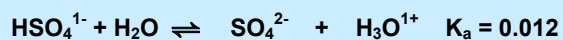

Initial	0.10	0	0.10	M
$\Delta$	-x	+x	+x	M
eq	0.10 - x	x	0.10 + x	M

If x is negligible,  $[\text{SO}_4^{2-}] = K_a = 0.012$  M, but that is 12% of the initial concentration, and the assumption is not valid. Substitution of the above into the  $K_a$  expression and rearrangement to the form of a quadratic equation leads to the following:

$$0.012 = \frac{(0.10 + x)(x)}{(0.10 - x)} = \frac{0.10 + x^2}{0.10 - x} \Rightarrow x^2 + 0.112x - 0.0012 = 0$$

Use the quadratic formula to solve for x.

$$x = [\text{SO}_4^{2-}] = \frac{-0.112 \pm \sqrt{(0.112)^2 - 4(1)(-0.0012)}}{2(1)} = 0.0098 \text{ M}$$

Use the value of x obtained above to determine the other unknowns

$$[\text{HSO}_4^{1-}] = 0.10 - 0.0098 = 0.09 \text{ M}; [\text{H}_3\text{O}^{1+}] = 0.10 + 0.0098 = 0.11 \text{ M};$$

$$\text{pH} = -\log(0.11) = 0.96.$$

**Example 6.13**

What are the pH and concentrations of all phosphorus-containing species in a 1.00 M  $\text{H}_3\text{PO}_4$  solution?

The first dissociation is  $\text{H}_3\text{PO}_4(\text{aq}) + \text{H}_2\text{O} \rightleftharpoons \text{H}_2\text{PO}_4^{1-} + \text{H}_3\text{O}^{1+}$   $K_1 = 7.5 \times 10^{-3}$

Assume negligible reaction to obtain  $[\text{H}_3\text{O}^{1+}] = \sqrt{(7.5 \times 10^{-3})(1.00)} = 0.087 \text{ M}$

$x/c_0$  is 0.087%, which is over 0.05, so we must solve the quadratic.

$$7.5 \times 10^{-3} = \frac{x^2}{1.00 - x}; \quad x^2 + 7.5 \times 10^{-3} x - 7.5 \times 10^{-3} = 0; \quad x = 0.083 \text{ M}$$

The concentrations of the other species involved in the first dissociation are

$$[\text{H}_3\text{PO}_4] = 1.00 - 0.083 = 0.92 \text{ M}; \quad [\text{H}_3\text{O}^{1+}] = [\text{H}_2\text{PO}_4^{1-}] = 0.083 \text{ M}$$

If the extent of the second dissociation is negligible compared to the first, then

$$[\text{HPO}_4^{2-}] = K_2 = 6.2 \times 10^{-8} \text{ M}$$

$6.2 \times 10^{-8} \text{ M}$  is negligible compared to 0.083 M and the assumption is valid. ✓

We now use the known concentrations in the third dissociation to determine the phosphate ion concentration.

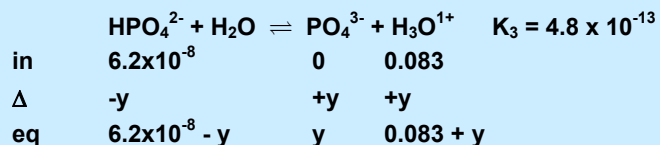

if  $y$  is negligible compared to  $6.2 \times 10^{-8}$ , then the  $K_a$  expression and  $y$  are

$$4.8 \times 10^{-13} = \frac{y(0.083)}{6.2 \times 10^{-8}}; \quad y = [\text{PO}_4^{3-}] = \frac{(4.8 \times 10^{-13})(6.2 \times 10^{-8})}{0.083} = 3.6 \times 10^{-19} \text{ M}$$

$y$  is negligible compared to  $6.2 \times 10^{-8} \text{ M}$ , so the assumption is valid. ✓

**6.6 STRONG BASES**

Strong bases are derived from metal hydroxides,  $\text{M}(\text{OH})_n$ . However, most metal hydroxides are insoluble in water, so the common bases are restricted to the hydroxides of a relatively small number of metals that have soluble hydroxides. The most common strong bases are NaOH, KOH, and  $\text{Ba}(\text{OH})_2$ . The concentration on the label indicates the makeup concentration of the base, which is related to the hydroxide ion concentration by the stoichiometry of the metal hydroxide as shown in Reaction 6.2.

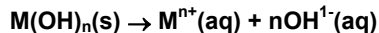

Rxn. 6.2

**PRACTICE EXAMPLE 6.5**

What are the pH, and the concentrations of all sulfur containing species in 0.064 M  $\text{H}_2\text{SO}_3$  solution?

Reaction table and equilibrium constant from Appendix H for the first dissociation:

Reaction \_\_\_\_\_  $K_1 =$   
in \_\_\_\_\_  
 $\Delta$  \_\_\_\_\_  
eq \_\_\_\_\_

a) Assume negligible reaction

$$[\text{H}_3\text{O}^{1+}] = \quad = \quad \text{M}$$

% ionization = \_\_\_\_\_%

Is assumption valid? \_\_\_\_\_

b) Solve the quadratic equation equilibrium constant expression

quadratic equation in terms of  $x$ :

$$[\text{H}_3\text{O}^{1+}] = \quad \text{M}$$

$$\text{pH} = \quad$$

$$[\text{HSO}_3^{1-}] = \quad \text{M}$$

$$[\text{H}_2\text{SO}_3] = \quad \text{M}$$

If  $K_2$  reaction is negligible,

$$[\text{SO}_3^{2-}] = \quad \text{M}$$

### Example 6.14

What is the pH of a solution labeled 0.16 M Ba(OH)<sub>2</sub> at 25 °C?

Ba(OH)<sub>2</sub> is a strong base and the process that occurs when it dissolves is

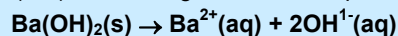

Thus, two moles of hydroxide ion are produced from each mole of Ba(OH)<sub>2</sub>,

$$[\text{OH}^{-}] = \frac{0.16 \text{ mol Ba(OH)}_2}{1 \text{ L solution}} \times \frac{2 \text{ mol OH}^{-}}{1 \text{ mol Ba(OH)}_2} = 0.32 \text{ M}$$

$$\text{pOH} = -\log(0.32) = 0.49; \quad \text{pH} = 14.00 - 0.49 = 13.51$$

## 6.7 WEAK BASES

Weak bases react with water to produce their conjugate acids and hydroxide ions. They can be treated in a manner analogous to weak acids. Consider the reaction table for the reaction of a generic base B<sup>1-</sup> with water.

	B <sup>1-</sup>	+	H <sub>2</sub> O	⇌	HB(aq)	+	OH <sup>1-</sup>	
initial	c <sub>0</sub>				0		0	M
Δ	-x				+x		+x	M
eq	c <sub>0</sub> - x				x		x	M

The equilibrium constant for the reaction is the K<sub>b</sub> of the base. Setting up the equilibrium constant expression, we obtain

$$K_b = \frac{[\text{HB}][\text{OH}^{-}]}{[\text{B}^{-}]} = \frac{(x)(x)}{c_0 - x} = \frac{x^2}{c_0 - x}$$

The K<sub>b</sub> expression is solved by using the quadratic formula or assuming that c<sub>0</sub> - x ≅ c<sub>0</sub>, in which case Equation 6.8 can be used.

$$[\text{OH}^{-}] = [\text{conjugate acid}] = \sqrt{K_b c_0} \quad \text{Eq. 6.8}$$

Equation 6.8 is valid only if less than 5% of the base reacts; *i.e.*, if x/c<sub>0</sub> < 0.05.\*

The K<sub>b</sub> of a weak base is related to the K<sub>a</sub> of its conjugate acid. The relationship can be seen by adding the K<sub>a</sub> reaction of the weak acid and the K<sub>b</sub> reaction of its conjugate base. The result is the autoionization reaction of water. For example, consider the sum of the K<sub>a</sub> reaction of ammonium ion and the K<sub>b</sub> reaction of ammonia.

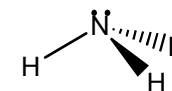

### Ammonia

Nitrogen atoms frequently have lone pairs in molecules, so their compounds are frequently weak bases. Ammonia is the simplest and most common such compound. It is a gas at normal conditions, but is most commonly encountered in aqueous solution, where its basicity makes it ideal for use as a cleaning fluid. Ammonia is the source of nitrogen in fertilizers, usually in the form of ammonium salts, plastics, vitamins, drugs, and many other chemicals. Large quantities of ammonia are also used in the production of nitric acid, which is needed to make such explosives as TNT (trinitrotoluene), nitroglycerin, and ammonium nitrate.

\* The 5% rule applies to bases as well as to acids.

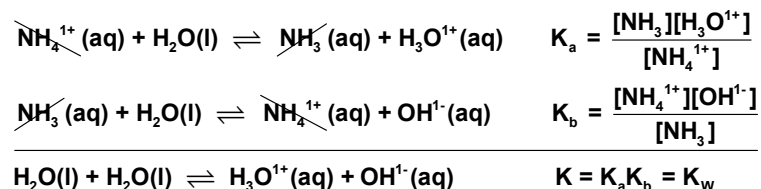

The autoionization reaction of water can be expressed as the sum of the  $K_a$  and  $K_b$  reactions of a conjugate acid-base pair, so  $K_w$  is the product of the  $K_a$  of an acid and the  $K_b$  of its conjugate base, i.e.,

$$K_a K_b = K_w = 1.0 \times 10^{-14} \text{ at } 25^\circ \text{C} \quad \text{Eq. 6.9}$$

Typically, only the  $K_a$  of the acid or the  $K_b$  of its conjugate base is tabulated. The number that is not tabulated is then determined with Equation 6.9. For example, the  $K_a$  of ammonium ion is listed in Appendix C, but the  $K_b$  of ammonia is not. Thus, the ammonia  $K_b$  is determined as follows:

$$K_b = \frac{K_w}{K_a} = \frac{1.0 \times 10^{-14}}{5.6 \times 10^{-10}} = 1.8 \times 10^{-5}$$

$K_a$  and  $K_b$  involve negative exponents, so they are frequently reported on the p-scale (Equation 6.2).

$$\text{p}K_a = -\log K_a \quad \text{and} \quad \text{p}K_b = -\log K_b \quad \text{Eq. 6.10}$$

Finally, we can take the logarithm of both sides of Equation 6.9 to obtain

$$\text{p}K_a + \text{p}K_b = \text{p}K_w = 14.00 \text{ at } 25^\circ \text{C} \quad \text{Eq. 6.11}$$

### Example 6.15

The  $\text{p}K_a$  of lactic acid is 3.89. What is the  $K_a$  of lactic acid?

Use Equation 6.3 to convert the  $\text{p}K_a$  to a  $K_a$ :  $K_a = 10^{-\text{p}K_a} = 10^{-3.89} = 1.3 \times 10^{-4}$

What is the  $K_b$  of the lactate ion?

Use Equation 6.10 to convert the  $\text{p}K_a$  of the acid into the  $\text{p}K_b$  of the conjugate base and then Equation 6.3 to convert the  $\text{p}K_b$  into the  $K_b$ :

$$\text{p}K_b = 14.00 - \text{p}K_a = 14.00 - 3.89 = 10.11$$

$$K_b = 10^{-\text{p}K_b} = 10^{-10.11} = 7.8 \times 10^{-11}$$

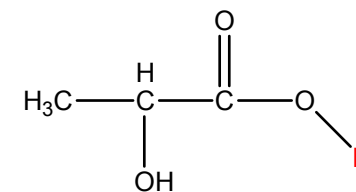

### Lactic acid

Lactic acid is usually prepared by fermentation, and the lactic acid generated by fermentation of lactose is responsible for the souring of milk. Lactic acid is used in the preparation of cheese, soft drinks, and other food products. Also, it is the presence of lactic acid in muscle that causes fatigue and even cramps. The acidic proton is highlighted in red.

### Example 6.16

What is the pH of a solution that is 0.12 M in  $\text{NO}_2^{1-}$ ?

The  $K_a$  of  $\text{HNO}_2$  in Appendix C is  $4.0 \times 10^{-4}$ , so the  $K_b$  of the nitrite ion can be determined from Equation 6.9 to be

$$K_b = \frac{1.0 \times 10^{-14}}{4.0 \times 10^{-4}} = 2.5 \times 10^{-11}$$

Proceed as with a weak acid and construct the reaction table for the reaction of nitrite ion with water.

	$\text{NO}_2^{1-}(\text{aq})$	$+$	$\text{H}_2\text{O}(\text{l})$	$\rightleftharpoons$	$\text{HNO}_2(\text{aq})$	$+$	$\text{OH}^{1-}(\text{aq})$
initial	0.12				0		0
$\Delta$	-x				+x		+x
eq.	0.12 - x				x		x

Substitute the concentrations into the  $K_b$  expression:  $2.5 \times 10^{-11} = \frac{(x)(x)}{0.12-x}$

$K_b$  is small and  $c_0$  is large, so assume  $x$  is negligible compared to 0.12 and solve for  $x = [\text{HNO}_2] = [\text{OH}^{1-}]$ .

$$x^2 = (0.12)(2.5 \times 10^{-11}) \Rightarrow x = \sqrt{3.0 \times 10^{-12}} = 1.7 \times 10^{-6} \text{ M}$$

$x/0.12 \ll 0.05$ , so assumption was valid. The hydroxide ion concentration is converted to pOH, which is then converted into the pH.

$$\text{pOH} = -\log [\text{OH}^{1-}] = -\log (1.7 \times 10^{-6}) = 5.76 \text{ and } \text{pH} = 14.00 - 5.76 = 8.24$$

Bases that can accept more than one proton are treated much the same way as polyprotic acids. Consider the case of the sulfide ion, which can accept two protons.

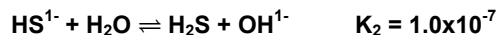

Note that the two  $K_b$  values differ by a factor of about a million. Thus, the hydroxide produced in the second step is negligible compared to that produced in the first step. Consequently, the hydroxide ion concentration in an aqueous solution of a base that can accept more than one proton salt can usually be determined by considering only the first step.

### PRACTICE EXAMPLE 6.6

The pH of a 0.085-M solution of methyl amine is 11.77. What is the  $K_b$  of methyl amine ( $\text{CH}_3\text{NH}_2$ )?

$K_b$  reaction:

---

$$[\text{OH}^{1-}] =$$

$$[\text{CH}_3\text{NH}_3^{1+}] =$$

$$[\text{CH}_3\text{NH}_2] =$$

$$K_b =$$

$$\text{p}K_b \text{ of } \text{CH}_3\text{NH}_2 =$$

Is  $[\text{OH}^{1-}]$  negligible compared to  $c_0$  in this solution? \_\_\_\_\_

What is the  $\text{p}K_a$  of the methyl ammonium ion?

$$\text{p}K_a \text{ of } \text{CH}_3\text{NH}_3^{1+} =$$

**Example 6.17**

What is the pH of a 0.064-M solution of sulfide ion?

First determine the  $K_b$  of  $S^{2-}$  from the  $K_a$  of its conjugate acid,  $HS^{1-}$ , which is in Appendix C

$$K_b = \frac{1.0 \times 10^{-14}}{1.3 \times 10^{-13}} = 0.077$$

The reaction table for the reaction of sulfide ion and water is

	$S^{2-}$	$+ H_2O(l)$	$\rightleftharpoons$	$HS^{1-}(aq)$	$+ OH^{1-}(aq)$
initial	0.064			0	0
$\Delta$	-x			+x	+x
eq.	0.064-x			x	x

Substitute the concentrations into the  $K_b$  expression  $0.077 = \frac{(x)(x)}{0.064 - x}$

If  $x$  is negligible compared to 0.064, then  $x = \sqrt{(0.077)(0.064)} = 0.070 \text{ M}$ , which is greater than  $c_0$ , so the assumption is clearly not valid. Rewrite the  $K_b$  expression and rearrange.

$$(0.077)(0.064) - 0.077x = x \quad \text{so} \quad x^2 + 0.077x - 0.0049 = 0$$

Solve with quadratic formula:  $x = \frac{-0.077 + \sqrt{(0.077)^2 - 4(1)(-0.0049)}}{2(1)} = 0.042 \text{ M}$

Check algebra:  $K_b = \frac{(0.042)(0.042)}{(0.064 - 0.042)} = 0.077$  ✓ Extra significant digits were used with  $x$ .

$$pOH = -\log [OH^{1-}] = -\log (0.042) = 1.38; \quad pH = 14.00 - 1.38 = 12.62$$

**PRACTICE EXAMPLE 6.7**

What are the concentrations of all sulfur-containing species in a 0.12-M solution of  $K_2SO_3$ ?

$K_b$  for first step

$K_1 =$  \_\_\_\_\_

reaction table for first step:

$$[HSO_3^{1-}] = \text{_____ M}$$

$$[SO_3^{2-}] = \text{_____ M}$$

$K_b$  for second step:

$K_2 =$  \_\_\_\_\_

Reaction table for second step

$$[H_2SO_3] = \text{_____ M}$$

**6.8 SALTS OF WEAK ACIDS AND BASES**

A **salt** is an ionic compound that is produced in an acid-base reaction. The acid-base properties of a salt depend upon the nature of both the anion and the cation. Although small, highly-charged cations do have acid properties (Section 8.1), those of the 1A metals have no acid-base properties and can be ignored in deciding the properties of the salt. Consequently, the discussion in this section assumes that all metal-containing salts are formed with Group 1A metal ions.

A **neutral salt** is the salt of a strong acid and a strong base. They are neutral because the cation is a metal ion and the anion is the conjugate base of a strong acid, so it does not behave like a base in water. Thus, NaCl is a neutral salt because neither  $Na^{1+}$  nor  $Cl^{1-}$  have acid-base properties in water (chloride ion does not react with water to produce HCl because HCl is a strong acid).

Most anions accept the positive charge of a proton, so anions are usually good bases, and salts containing them are basic salts. **Basic salts** are formed in the reaction of weak acids with strong bases. For example, the reaction of HCN and NaOH produces the basic salt NaCN:  $\text{HCN} + \text{NaOH} \rightarrow \text{H}_2\text{O} + \text{NaCN}$ . NaCN produces  $\text{Na}^{1+}$  and  $\text{CN}^{1-}$  ions when it dissolves in water. The  $\text{Na}^{1+}$  ions can be ignored, but  $\text{CN}^{1-}$  is a weak base.



Basic salts are the most common source of weak bases.

**Acidic salts** are produced by the reaction of strong acids with weak bases. For example, the reaction of HCl with  $\text{NH}_3$  produces the acidic salt  $\text{NH}_4\text{Cl}$ :  $\text{NH}_3 + \text{HCl} \rightarrow \text{NH}_4\text{Cl}$ .  $\text{NH}_4\text{Cl}$  is an acidic salt because the ammonium ion is a weak acid, but chloride ion is not a weak base in water. Thus, dissolving  $\text{NH}_4\text{Cl}$  produces ammonium ions, which react with water to produce hydronium ions ( $\text{NH}_4^{1+} + \text{H}_2\text{O} \rightleftharpoons \text{NH}_3 + \text{H}_3\text{O}^{1+}$ ).

The acid-base properties of a salt formed from the reaction of a weak base and a weak acid depend upon the relative values of the  $K_a$  of the acid and the  $K_b$  of the base. They are acidic when  $K_a > K_b$ , basic when  $K_b > K_a$ , or neutral when  $K_a = K_b$ . Example 6.18 gives some examples.

### Example 6.18

Indicate whether a solution of each of the following salts is acidic, basic, or neutral.

**a)  $\text{KClO}_4$**

The cation is a 1A metal and  $\text{ClO}_4^{1-}$  is the conjugate base of a strong acid, so neither ion reacts with water, which makes  $\text{KClO}_4$  a neutral salt.

**b)  $\text{Na}_2\text{S}$**

The cation can be ignored but,  $\text{S}^{2-}$  is a weak base, so  $\text{Na}_2\text{S}$  is a basic salt.

**c)  $\text{NH}_4\text{NO}_2$**

$\text{NH}_4^{1+}$  is a weak acid, and  $\text{NO}_2^{1-}$  is a weak base. The  $K_a$  of  $\text{NH}_4^{1+}$  is  $5.6 \times 10^{-10}$ , and the  $K_b$  of  $\text{NO}_2^{1-}$  is  $K_w/K_a(\text{HNO}_2) = (1.0 \times 10^{-14})/(4.0 \times 10^{-4}) = 2.5 \times 10^{-11}$ . The  $K_a$  of  $\text{NH}_4^{1+}$  is greater than the  $K_b$  of  $\text{NO}_2^{1-}$ , so the salt is an acidic salt.

**d)  $(\text{NH}_4)_3\text{PO}_4$**

$\text{NH}_4^{1+}$  is a weak acid, and  $\text{PO}_4^{3-}$  is a weak base. The  $K_a$  of  $\text{NH}_4^{1+}$  is  $5.6 \times 10^{-10}$ , and the  $K_b$  of  $\text{PO}_4^{3-}$  is  $K_w/K_a(\text{HPO}_4^{2-}) = (1.0 \times 10^{-14})/(4.8 \times 10^{-13}) = 2.1 \times 10^{-2}$ . The  $K_b$  of  $\text{PO}_4^{3-}$  is greater than the  $K_a$  of  $\text{NH}_4^{1+}$ , so the salt is a basic salt.

### PRACTICE EXAMPLE 6.8

What is the pH of a solution prepared by dissolving 3.5 g of KF ( $M_m = 58.1 \text{ g}\cdot\text{mol}^{-1}$ ) in sufficient water to make 150 mL of solution?

KF is a(n) \_\_\_\_\_ salt because the \_\_\_\_\_ ion is a(n) \_\_\_\_\_, while the \_\_\_\_\_ ion is neither acidic nor basic in water.

$$K_b = \text{_____} = \text{_____}$$

Moles of KF:

$$\text{_____} \times \text{_____} = \text{_____} \text{ mol}$$

Fluoride ion concentration:

$$[\text{F}^{1-}] = \text{_____} = \text{_____} \text{ M}$$

Reaction Table:

Reaction:

In

$\Delta$

Eq

Hydroxide ion concentration from Equation 6.8:

$$[\text{OH}^{1-}] = \text{_____} = \text{_____} \text{ M}$$

Is the assumption made in Eq. 6.8 valid? \_\_\_\_\_

$$\text{pOH} =$$

$$\text{pH} =$$

e)  $\text{NH}_4\text{C}_2\text{H}_3\text{O}_2$ 

$\text{NH}_4^{1+}$  is a weak acid, and  $\text{C}_2\text{H}_3\text{O}_2^{1-}$  is a weak base. The  $K_a$  of  $\text{NH}_4^{1+}$  is  $5.6 \times 10^{-10}$ , and the  $K_b$  of  $\text{C}_2\text{H}_3\text{O}_2^{1-}$  is  $K_w/K_a(\text{HC}_2\text{H}_3\text{O}_2) = (1.0 \times 10^{-14})/(1.8 \times 10^{-5}) = 5.6 \times 10^{-10}$ . The  $K_b(\text{C}_2\text{H}_3\text{O}_2^{1-}) = K_a(\text{NH}_4^{1+})$ , so the salt is a neutral salt.

## 6.9 AMPHIPROTIC SALTS

As shown in Figure 6.3,  $\text{HCO}_3^{1-}$  is an amphiprotic substance because it can behave as both an acid and a base. It produces hydronium ion through its  $K_a$  reaction

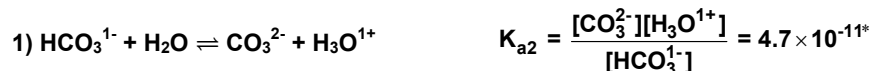

For every mole of hydronium produced, a mole of carbonate ion is also produced; *i.e.*,

$$[\text{H}_3\text{O}^{1+}]_{\text{produced}} = [\text{CO}_3^{2-}]$$

The concentration of hydronium ion produced in this step equals the equilibrium concentration of its conjugate base, carbonate ion. However,  $\text{HCO}_3^{1-}$  also produces hydroxide ion through its  $K_b$  reaction.



$K_{b1} = K_w/K_{a2} = 1.0 \times 10^{-14}/4.7 \times 10^{-11}$ . For every mole of hydroxide ion produced, a mole of carbonic acid is also produced; *i.e.*,  $[\text{OH}^{1-}]_{\text{produced}} = [\text{H}_2\text{CO}_3]$ . Each mole of hydroxide ion that is produced, consumes a mole of hydronium ion ( $\text{H}_3\text{O}^{1+} + \text{OH}^{1-} \rightarrow 2\text{H}_2\text{O}$ ). Thus,

$$[\text{OH}^{1-}]_{\text{produced}} = [\text{H}_3\text{O}^{1+}]_{\text{consumed}} = [\text{H}_2\text{CO}_3]$$

The equilibrium hydronium ion concentration is

$$[\text{H}_3\text{O}^{1+}] = [\text{H}_3\text{O}^{1+}]_{\text{produced}} - [\text{H}_3\text{O}^{1+}]_{\text{consumed}} = [\text{CO}_3^{2-}] - [\text{H}_2\text{CO}_3]$$

The concentrations of  $\text{CO}_3^{2-}$  and  $\text{H}_2\text{CO}_3$  can be obtained from  $K_{a2}$  and  $K_{b1}$

$$[\text{H}_3\text{O}^{1+}] = [\text{CO}_3^{2-}] - [\text{H}_2\text{CO}_3] = \frac{K_{a2}[\text{HCO}_3^{1-}]}{[\text{H}_3\text{O}^{1+}]} - \frac{K_{b1}[\text{HCO}_3^{1-}]}{[\text{OH}^{1-}]}$$

Use  $K_{b1} = K_w/K_{a1}$  and then  $K_w = [\text{H}_3\text{O}^{1+}][\text{OH}^{1-}]$  to convert the second term from a function of  $K_{b1}$  and  $\text{OH}^{1-}$  to one of  $K_{a1}$  and  $[\text{H}_3\text{O}^{1+}]$ :

$$\frac{K_{b1}}{[\text{OH}^{1-}]} = \frac{K_w}{K_{a1}[\text{OH}^{1-}]} = \frac{[\text{H}_3\text{O}^{1+}][\text{OH}^{1-}]}{K_{a1}[\text{OH}^{1-}]} = \frac{[\text{H}_3\text{O}^{1+}]}{K_{a1}}$$

\* We use the following notation:

$$K_{a1} = K_a \text{ of } \text{H}_2\text{CO}_3$$

$$K_{a2} = K_a \text{ of } \text{HCO}_3^{1-}$$

$$K_{b1} = K_b \text{ of } \text{HCO}_3^{1-}$$

$$K_{b2} = K_b \text{ of } \text{CO}_3^{2-}$$

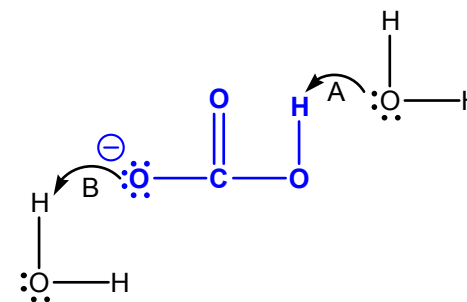

**Figure 6.3 Amphiprotic substances are acids and bases.**

$\text{HCO}_3^{1-}$  is amphiprotic because its acidic proton can be lost (Arrow A) or the lone pair on the oxygen with negative formal charge can accept a proton (Arrow B).

Express the hydronium ion concentration with the changes in the second term

$$[\text{H}_3\text{O}^{1+}] = \frac{K_{a2}[\text{HCO}_3^{1-}]}{[\text{H}_3\text{O}^{1+}]} - \frac{[\text{H}_3\text{O}^{1+}][\text{HCO}_3^{1-}]}{K_{a1}}$$

Multiply both sides of the equation by the hydronium ion concentration to obtain

$$[\text{H}_3\text{O}^{1+}]^2 = K_{a2}[\text{HCO}_3^{1-}] - \frac{[\text{H}_3\text{O}^{1+}]^2[\text{HCO}_3^{1-}]}{K_{a1}}$$

Solve the preceding for the square of the hydronium ion concentration

$$[\text{H}_3\text{O}^{1+}]^2 = \frac{K_{a1}K_{a2}[\text{HCO}_3^{1-}]}{K_{a1} + [\text{HCO}_3^{1-}]}$$

The extents of both the  $K_{a2}$  and  $K_{b1}$  reactions of  $\text{HCO}_3^{1-}$  are small, so little  $\text{HCO}_3^{1-}$  reacts and  $[\text{HCO}_3^{1-}] \gg K_{a1}$  for normal concentrations. Thus,  $K_{a1}$  is negligible in the addition term in the denominator. Substitution of  $[\text{HCO}_3^{1-}]$  for  $K_{a1} + [\text{HCO}_3^{1-}]$  yields

$$[\text{H}_3\text{O}^{1+}]^2 = \frac{K_{a1}K_{a2}[\text{HCO}_3^{1-}]}{[\text{HCO}_3^{1-}]} = K_{a1}K_{a2}$$

Taking the negative *log* of both sides and solving for the pH, we obtain the final result

$$\text{pH} = \frac{1}{2}(\text{p}K_{a1} + \text{p}K_{a2}) \quad \text{Eq. 6.12}$$

The pH of an amphiprotic substance is half-way between its  $\text{p}K_a$  ( $\text{p}K_{a2}$ ) and that of its conjugate acid ( $\text{p}K_{a1}$ ) so long as its concentration is much larger than the  $K_a$  of its conjugate acid,  $K_{a1}$ .

### Example 6.19

**What is the pH of a 0.116-M solution of  $\text{K}_2\text{HPO}_4$ ?**

First obtain the  $\text{p}K_a$  values of the amphiprotic substance:  $\text{p}K_2 = \text{p}K_a(\text{HPO}_4^{2-}) = 12.32$  and that of its conjugate acid:  $\text{p}K_1 = \text{p}K_a(\text{H}_2\text{PO}_4^{1-}) = 7.21$ . The concentration is irrelevant, and Equation 6.12 can be used to get the pH.

$$\text{pH} = \frac{1}{2}(\text{p}K_1 + \text{p}K_2) = \frac{1}{2}(7.21 + 12.32) = 9.77$$

## 6.10 CHAPTER SUMMARY AND OBJECTIVES

It takes only small concentrations of hydronium or hydroxide ion to make a solution acidic or basic. Because the concentrations are typically quite small, they are often expressed on the p-scale:  $\text{pH} = -\log [\text{H}_3\text{O}^{1+}]$  and  $\text{pOH} = -\log [\text{OH}^{1-}]$ . Water is both a weak acid and a weak base. As a result, water molecules react with one another to a small extent. The equilibrium constant for the reaction,  $\text{H}_2\text{O} + \text{H}_2\text{O} \rightleftharpoons \text{H}_3\text{O}^{1+} + \text{OH}^{1-}$ , is  $K_w = [\text{H}_3\text{O}^{1+}][\text{OH}^{1-}] = 1.0 \times 10^{-14}$ .  $K_w$  must be satisfied in all aqueous solutions. Consequently, if either the hydronium or hydroxide ion concentration of a solution is known, the concentration of the other ion can be determined with  $K_w$ . In a neutral solution,  $[\text{H}_3\text{O}^{1+}] = [\text{OH}^{1-}]$  and  $\text{pH} = \text{pOH} = 7$ .

Weak acids react to only a small extent with water, so their  $K_a$  values are less than one. The amount of acid reacting can be assumed to be negligible compared to its initial concentration if less than 5% reacts. In this case, the following approximation can be used:  $[\text{H}_3\text{O}^{1+}] = [\text{conjugate base}] = \sqrt{K_a c_o}$ . If more than 5% reacts, a quadratic equation must be solved.

Acids with more than one acidic proton are said to be polyprotic. The  $K_a$  values for the acids formed by removal of successive protons usually differ by several orders of magnitude, so the hydronium ion concentration in a polyprotic acid solution comes almost entirely from the first ionization reaction, and the pH is determined in the same way as a monoprotic acid. An important exception is the strong acid  $\text{H}_2\text{SO}_4$ .

Bases react with water to produce  $\text{OH}^{1-}$  ion and the equilibrium constant for the reaction is termed the  $K_b$  of the base. The  $K_a$  of an acid and the  $K_b$  of its conjugate base are related by the expression:  $K_a K_b = K_w$ . Consequently, the  $K_b$  of a weak base can be determined from the  $K_a$  of its conjugate acid. Equilibria mixtures of bases are treated in a manner very similar to that of weak acids. When the extent of reaction is small, the following approximation can be used:  $[\text{OH}^{1-}] = [\text{conjugate acid}] = \sqrt{K_b c_o}$ . A quadratic equation must be solved if more than 5% of the base reacts.

Salts are the ionic products of acid-base reactions. They are frequently basic because most anions are weak bases. However, when the anion is the conjugate base of a strong acid, the salt is neutral because the anion is too weak a base to remove a proton from water and form  $\text{OH}^{1-}$ . Protonated anions can be acidic as is the ammonium ion. Consequently, salts like  $\text{KHSO}_4$  and  $\text{NH}_4\text{Cl}$  are acidic salts. The acid-base properties of salts that contain

## ANSWERS TO PRACTICE EXAMPLES

- 6.1 a)  $[\text{H}_3\text{O}^{1+}] = 4.8 \times 10^{-3} \text{ M}$ ;  $[\text{OH}^{1-}] = 2.1 \times 10^{-12} \text{ M}$   
 b)  $\text{pH} = 11.92$ ;  $\text{pOH} = 2.08$ ;  $[\text{H}_3\text{O}^{1+}] = 1.2 \times 10^{-12}$
- 6.2  $\text{pH} = 5.17$
- 6.3  $c_o = 0.018 \text{ M}$
- 6.4  $\text{pH} = 3.56$   $[\text{H}_2\text{CO}_3] = 0.18 \text{ M}$   
 $[\text{HCO}_3^{1-}] = 2.8 \times 10^{-4} \text{ M}$   $[\text{CO}_3^{2-}] = 4.7 \times 10^{-11} \text{ M}$
- 6.5 a)  $K_1 = 0.015$   $[\text{H}_3\text{O}^{1+}] = 0.031 \text{ M}$  No  
 b)  $[\text{H}_3\text{O}^{1+}] = 0.024 \text{ M} = [\text{HSO}_3^{1-}]$ ;  
 $x^2 + 0.015x - 9.6 \times 10^{-4} = 0$   
 $\text{pH} = 1.62$ ;  $[\text{H}_2\text{SO}_3] = 0.040 \text{ M}$
- c)  $[\text{SO}_3^{2-}] = K_2 = 1.0 \times 10^{-7} \text{ M}$
- 6.6  $K_b = 4.4 \times 10^{-4}$ ;  $\text{p}K_b = 3.36$ ;  $\text{p}K_a = 10.64$
- 6.7  $K_1 = 1.0 \times 10^{-7}$ ;  $[\text{SO}_3^{2-}] = 0.12 \text{ M}$ ;  $[\text{HSO}_3^{1-}] = 1.1 \times 10^{-4} \text{ M}$   
 $[\text{H}_2\text{SO}_3] = 6.7 \times 10^{-13} \text{ M}$
- 6.8 KF is a basic salt because the fluoride ion is a base, while the potassium ion is neither.  $[\text{F}^{1-}] = 0.40 \text{ M}$ ;  
 $[\text{OH}^{1-}] = 2.4 \times 10^{-6} \text{ M}$ ;  $\text{pH} = 8.37$

both an acid and a base depend upon the relative strengths of the acid and the base.

Amphiprotic materials are anions with acidic protons, so they can act as both acids and bases. The pH of an amphiprotic substance is half-way between its  $pK_a$  ( $pK_2$ ) and that of its conjugate acid ( $pK_1$ ); *i.e.*,  $pH = \frac{1}{2}(pK_1 + pK_2)$  for an amphiprotic substance.

After studying the material presented in this chapter, you should be able to:

1. convert between pH and  $[H_3O^{1+}]$ , pOH and  $[OH^{1-}]$  (Section 6.1);
2. determine  $[H_3O^{1+}]$ ,  $[OH^{1-}]$ , pH and pOH of a solution of a strong acid or strong base of known concentration (Section 6.2);
3. calculate the pH of a solution prepared by mixing a strong acid and a strong base (Section 6.3);
4. write the  $K_a$  expression for a weak acid (Sections 6.4);
5. determine the pH and equilibrium concentrations of all species present in solutions of weak acids (Sections 6.4);
6. determine one unknown (the pH of the solution, the  $K_a$  of the acid, or initial concentration of the acid) in a solution of a weak acid given the other two (Section 6.4);
7. calculate the percent ionization of a weak acid (Section 6.4);
8. convert between  $pK_a$  and  $K_a$  (Section 6.4);
9. determine the concentrations of all species in a solution of a polyprotic acid of known concentration (Section 6.5);
10. determine the pH of a strong base solution (Section 6.6)
11. write the  $K_b$  expression for a weak base (Sections 6.7);
12. determine the equilibrium concentrations of all species present in and the pH of solutions of weak bases (Sections 6.7);
13. determine one variable (the pH of the solution, the  $K_b$  of the base, or initial concentration of the base) in a solution of a weak base given the other two (Section 6.7);
14. convert between  $pK_b$  and  $K_b$  (Section 6.7);
15. convert between the  $K_a$  and  $K_b$  of a conjugate acid-base pair (Section 6.7);
16. define the term salt and predict whether a salt is neutral, basic, or acidic (Section 6.8);  
and
17. determine the pH of a solution of an amphiprotic salt (Section 6.9).

## 6.9 EXERCISES

## ACID-BASE TERMS AND A REVIEW OF ACID-BASE THEORY FROM CAMS CHAPTER 12

- Define a conjugate acid-base pair.
- Indicate the conjugate acid for each of the following:  
a)  $\text{OH}^{1-}$     b)  $\text{NO}_2^{1-}$     c)  $\text{NH}_2^{1-}$     d)  $\text{PO}_4^{3-}$     e)  $\text{HSO}_3^{1-}$
- Indicate the conjugate base for each of the following:  
a)  $\text{OH}^{1-}$     b)  $\text{H}_2\text{O}_2$     c)  $\text{H}_2\text{PO}_4^{1-}$     d)  $\text{H}_3\text{O}^{1+}$     e)  $\text{H}_2\text{SO}_3$
- Define a Lewis acid and a Brønsted acid. Give an example of a Lewis acid that is not a Brønsted acid.
- Are all Brønsted bases also Lewis bases? Explain.
- What distinguishes a weak acid from a strong one?
- Which of the following are Brønsted bases?  
a) NaOH    b) NaCl    c)  $\text{CH}_3\text{OH}$     d) KCN    e)  $\text{KH}_2\text{PO}_4$
- Which of the following are Brønsted acids?  
a) HClO    b)  $\text{CaH}_2$     c)  $\text{CH}_3\text{CO}_2\text{H}$     d)  $\text{KHSO}_3$     e)  $\text{NH}_4\text{Cl}$
- Explain how the reaction  $\text{Ag}^{1+} + \text{Cl}^{1-} \rightarrow \text{AgCl}$  is a Lewis acid-base reaction. Is it also a Brønsted acid-base reaction? Explain.
- Write Brønsted acid-base reactions or indicate *no reaction* if  $K \ll 1$ .  
a) Hydrochloric acid and aqueous sodium hydroxide are mixed.  
b) Aqueous potassium fluoride is added to perchloric acid.  
c) Aqueous  $\text{NH}_4\text{Cl}$  is added to aqueous  $\text{KHSO}_4$ .  
d) Aqueous ammonia is added to hydrofluoric acid.  
e)  $\text{HNO}_2$  is added to aqueous KF.
- Write Brønsted acid-base reactions or indicate *no reaction* if  $K \ll 1$ .  
a) Aqueous sodium sulfate is added to hydrobromic acid.  
b) Aqueous  $\text{NH}_4\text{Cl}$  and aqueous KF are mixed.  
c) Aqueous NaCN is added to a large excess of sulfurous acid.  
d) Acetic acid and aqueous sodium hypochlorite are mixed.  
e) Hydrogen sulfide is bubbled into water.
- Explain why  $\text{HClO}_4$  is a strong acid, but HClO is a weak acid.
- Explain why HCl is a strong acid, but HF is a weak acid.
- What is the predominate phosphorus containing species in a solution prepared by adding sodium phosphate to an excess of carbonic acid?

- What is the predominate phosphorus containing species in a solution prepared by adding phosphoric acid to a large excess of ammonia?
- Define *amphiprotic*. Identify the amphiprotic species in Exercises 2 & 3.
- What is an *autoionization* reaction? Write the chemical equation for the autoionization of ammonia.  $\text{H}_3\text{O}^{1+}$  and  $\text{OH}^{1-}$  are the strongest acid and base that can exist in aqueous solutions because water reacts with any acids or bases that are stronger than these acids. This is known as the *leveling effect*. What are the strongest acid and base that can exist in liquid ammonia?

In the remaining exercises, assume a temperature of 25 °C if none is given; that is, assume that  $K_w = 1.0 \times 10^{-14}$  if no temperature is given.

## THE p-SCALE

- Determine the hydronium and hydroxide ion concentrations in the following solutions:  
a) rainwater; pH = 5.3    b) household ammonia; pH = 11.9  
c) vinegar; pH = 2.7    d) seawater; pH = 7.6
- Determine the hydronium and hydroxide ion concentrations in the following solutions:  
a) detergent; pH = 10.3    b) stomach acid; pH = 2.4  
c) beer; pH = 4.2    d) milk of magnesia; pH = 10.5
- Determine the  $\text{pK}_a$  of each of the following acids:  
a) Hypoiodous acid     $\text{HIO}$      $K_a = 2.3 \times 10^{-11}$   
b) Iodic acid     $\text{HIO}_3$      $K_a = 0.16$
- Determine the  $\text{pK}_a$  of each of the following acids:  
a) Tartaric acid     $\text{H}_2\text{C}_4\text{H}_4\text{O}_6$      $K_a = 1.0 \times 10^{-3}$   
b) Boric acid     $\text{H}_3\text{BO}_3$      $K_a = 5.8 \times 10^{-10}$
- Determine the  $K_a$  of each of the following acids:  
a) Phenol     $\text{C}_6\text{H}_5\text{OH}$      $\text{pK}_a = 10.00$   
b) Ascorbic acid     $\text{H}_2\text{C}_6\text{H}_6\text{O}_6$      $\text{pK}_a = 4.10$
- Determine the  $K_a$  of each of the following acids:  
a) Hypobromous acid    HOBr     $\text{pK}_a = 8.64$   
b) Saccharin     $\text{HNC}_7\text{H}_4\text{SO}_3$      $\text{pK}_a = 11.68$
- What is the  $\text{pK}_b$  of the conjugate base of each acid in Exercise 20?
- What is the  $\text{pK}_b$  of the conjugate base of each acid in Exercise 21?

26. Determine the pH of solutions with the following pOH's:  
 a) 12.32                    b) 1.86                    c) 4.37
27. What is the  $K_a$  of an acid whose conjugate base has the following  $pK_b$ ?  
 a) 8.37                    b) 12.66                    c) 0.22

### AUTOIONIZATION AND pH

28. Determine the pH and pOH of solutions with the following hydronium ion concentrations:  
 a)  $3.4 \times 10^{-6}$  M                    b)  $4.7 \times 10^{-3}$  M                    c)  $8.8 \times 10^{-10}$  M
29. Determine the pH and pOH of solutions with the following hydroxide ion concentrations:  
 a)  $7.5 \times 10^{-8}$  M                    b)  $3.9 \times 10^{-4}$  M                    c)  $1.0 \times 10^{-12}$  M
30. What is the pH of  $1.0 \times 10^{-8}$  M HCl at 25 °C? Hint: At such a low acid concentration water is the primary source of  $H_3O^{1+}$  in the solution.
31. The solubility of  $Al(OH)_3$  in water is  $2.9 \times 10^{-9}$  M at 25 °C. What is the pH of a saturated solution of  $Al(OH)_3$  at 25 °C? Hint: What is the primary source of hydroxide ion in the solution?
32. The pH of water at 100 °C is 6.13. What is the value of  $K_w$  at 100 °C?

**Exercises 33-36 deal with solutions at 37 °C, the temperature of the human body.  $K_w = 2.42 \times 10^{-14}$  at this temperature.**

33. What is pH of a neutral solution at 37 °C?
34. What is the  $K_b$  of a base if  $K_a = 5.0 \times 10^{-10}$  at 37 °C for its conjugate acid?
35. What is the  $pK_b$  of a base if the  $pK_a$  of its conjugate acid is 5.21 at 37 °C?
36. The hydroxide ion concentration in a weak base solution at 37 °C is 0.024. What is the pH of the solution?

### STRONG ACIDS AND STRONG BASES

37. What is the pH of each of the following aqueous solutions?  
 a) 0.066 M HCl                    b) 0.21 M KOH                    c) 0.11 M  $Ba(OH)_2$
38. What is the pH of each of the following aqueous solutions?  
 a) 0.57 M NaOH                    b)  $1.3 \times 10^{-4}$  M  $HNO_3$                     c) 2.1 M KOH
39. To what volume must 5.0 mL of 6.0 M HCl be diluted to prepare a solution with pH = 1.22?

40. How much water must be added to 25 mL of an HCl solution with a pH = 2.46 to make a pH = 4.00 solution? Assume the volumes are additive.
41. What volume of HCl gas measured at 300. K and 1 atm is required to prepare 5.0 L of hydrochloric acid with a pH of 3.84?
41. 512 mL of HCl gas at 300. K and 886 torr is dissolved in water. What is the pH of the resulting solution if the total volume is 653 mL
43. How many grams of  $Ba(OH)_2$  would have to be dissolved in water to prepare 500.0 mL of a pH= 9.80 solution?
44. To what volume should 2.6 mL of 0.11 M NaOH be diluted in order to make a pH = 12.00 solution?

### WEAK ACIDS

45. What is the 5% rule?
46. Use the 5% rule to determine if the equilibrium concentration of the acid can be approximated by its makeup concentration.  
 a) 2.0 M HF                    b)  $2.0 \times 10^{-4}$  M  $H_2S$                     c) 0.10 M  $HNO_2$
47. Use the 5% rule to determine if the equilibrium concentration of the acid can be approximated by its makeup concentration.  
 a) 0.80 M cyanic acid ( $HCNO$ ,  $pK_a = 3.46$ )  
 b)  $4.4 \times 10^{-3}$  M hydrazoic acid ( $HN_3$ ,  $pK_a = 4.6$ )  
 c) 3.0 M arsenic acid ( $H_3AsO_4$ ,  $pK_a = 2.26$ )
48. Calculate the pH of a 0.25 M phenol ( $C_6H_5OH$ ,  $K_a = 1.0 \times 10^{-10}$ ), which is often used as an antiseptic.
49. What is the pH of vinegar, a 4.5% solution of acetic acid? Assume the density of the solution is  $1.0 \text{ g}\cdot\text{mL}^{-1}$ .
50. The pH of a 0.030 M benzoic acid solution is 2.85. What are  $K_a$  and  $pK_a$  of benzoic acid? What are  $K_b$  and  $pK_b$  of the benzoate ion?
51. What is the hypochlorite ion concentration in a 0.14 M solution of HOCl? What is the pH of the solution?
52. What is the fluoride ion concentration in 2.0 M HF?
53. What is the pH of 0.044 M HF?
54. What is the phosphate ion concentration in 0.066 M  $H_3PO_4$ ?
55. What is the  $K_a$  of chloroacetic acid,  $ClCH_2COOH$ , if a 0.085-M solution has a pH of 2.00?

56. What is the  $K_a$  of an acid if a 0.21-M solution is 3.4% dissociated?
57. What is the  $pK_a$  of iodic acid if the iodate ion concentration in a 0.066-M solution of  $HIO_3$  is 0.050 M?
58. What is the percent dissociation of 0.048 M propanoic acid ( $pK_a = 4.86$ )?
59. What is the percent dissociation of 0.26 M uric acid ( $pK_a = 3.89$ )?
60. What is the percent dissociation of 0.15 M iodic acid ( $pK_a = 0.77$ )?
61. What mass of ammonium chloride is required to prepare 500. mL of a solution with a pH of 4.62?
62. What mass of potassium hydrogensulfate is required to make 350. mL of a solution with a pH of 2.50?

### POLYPROTIC ACIDS

63. Vitamin C is ascorbic acid,  $H_2C_6H_6O_6$ ,

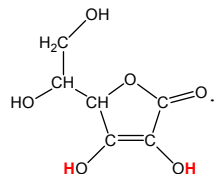

Calculate the pH,  $[C_6H_8O_6]$ ,  $[C_6H_7O_6^{1-}]$  and  $[C_6H_5O_6^{2-}]$  in a 0.075-M solution of ascorbic acid.

64. Oxalic acid ( $H_2C_2O_4$ ) is a diprotic acid with two carboxylic acid group that occurs naturally in some plants. Calculate the pH and the concentrations of all species present in a 0.25-M solution.
65. What are concentrations of all species in a 0.16-M solution of malonic acid ( $H_2C_3H_2O_4$ )?  $K_1 = 1.5 \times 10^{-3}$  and  $K_2 = 2.0 \times 10^{-6}$

### WEAK BASES & BASIC SALTS

66. Calculate the pH of a 0.50-M solution of pyridine ( $C_6H_5N$ ,  $K_b = 1.7 \times 10^{-9}$ ).
67. Industrial bleach is 15%  $NaClO$  by mass. What is the hypochlorous acid concentration in industrial bleach? Household bleach is a 5.25% solution of  $NaOCl$ . What is its pH? Assume a density of  $1.0 \text{ g}\cdot\text{mL}^{-1}$  for each solution.
68. What are the  $HF$  concentration and pH of 0.32 M  $KF$ ?
69. What are the  $NH_4^{1+}$  concentration and pH of a 0.16-M solution of  $NH_3$ ?

70. The pH of a 0.068-M solution of methyl amine ( $CH_3NH_2$ ) is 11.72. What are the  $K_b$  and  $pK_b$  of methylamine? What are the  $K_a$  and  $pK_a$  of the methylammonium ion?
71. The pH of 0.083 M aniline ( $C_6H_5NH_2$ ) is 8.76. What are its  $K_b$  and  $pK_b$ ?
72. How many grams of  $KCN$  are required to prepare 250. mL of a pH = 11.15 solution.
73. What percent of the ammonia molecules in a 0.12-M solution have reacted to produce ammonium ions?
74. What percent of the acetate ions in a 0.060-M solution of potassium acetate react to produce acetic acid molecules?
75. What are the concentrations of all phosphorus containing species in 0.084 M  $K_3PO_4$ ? What is the pH of the solution?
76. What are the concentrations of all carbon-containing species in 0.041 M  $K_2CO_3$ ?

### SALTS

77. Define the term *salt*. Give an example of a neutral, a basic, and an acidic salt.
78. Explain why all anions are not bases in water. Give examples of two anions that are not bases for different reasons.
79. Indicate whether each salt is acidic, basic, or neutral.
- |              |              |              |
|--------------|--------------|--------------|
| a) $K_2SO_4$ | b) $K_2SO_3$ | c) $KHSO_4$  |
| d) $K_2CO_3$ | e) $KClO$    | d) $NH_4ClO$ |
80. Indicate whether each salt is acidic, basic, or neutral.
- |            |                   |                   |
|------------|-------------------|-------------------|
| a) $NH_4F$ | b) $NH_4HSO_4$    | c) $(NH_4)_3PO_4$ |
| d) $KNO_3$ | e) $(NH_4)_2CO_3$ | f) $NaF$          |
81. What is the pH of each of the following salt solutions?
- |                    |                  |                    |
|--------------------|------------------|--------------------|
| a) 0.12 M $NH_4Cl$ | b) 0.096 M $KCN$ | c) 0.10 M $KHSO_3$ |
|--------------------|------------------|--------------------|
82. What is the pH of each of the following salt solutions?
- |                 |                       |                       |
|-----------------|-----------------------|-----------------------|
| a) 0.12 M $KCl$ | b) 0.086 M $KH_2PO_4$ | c) 0.088 M $Na_2SO_3$ |
|-----------------|-----------------------|-----------------------|